



2409 Plantside Drive
 Jeffersontown, KY 40299
 Customer Service: 800-626-1126
 www.rev-a-shelf.com

Mixer Lift Instructions
 RAS-ML-HDCR



FIG. A

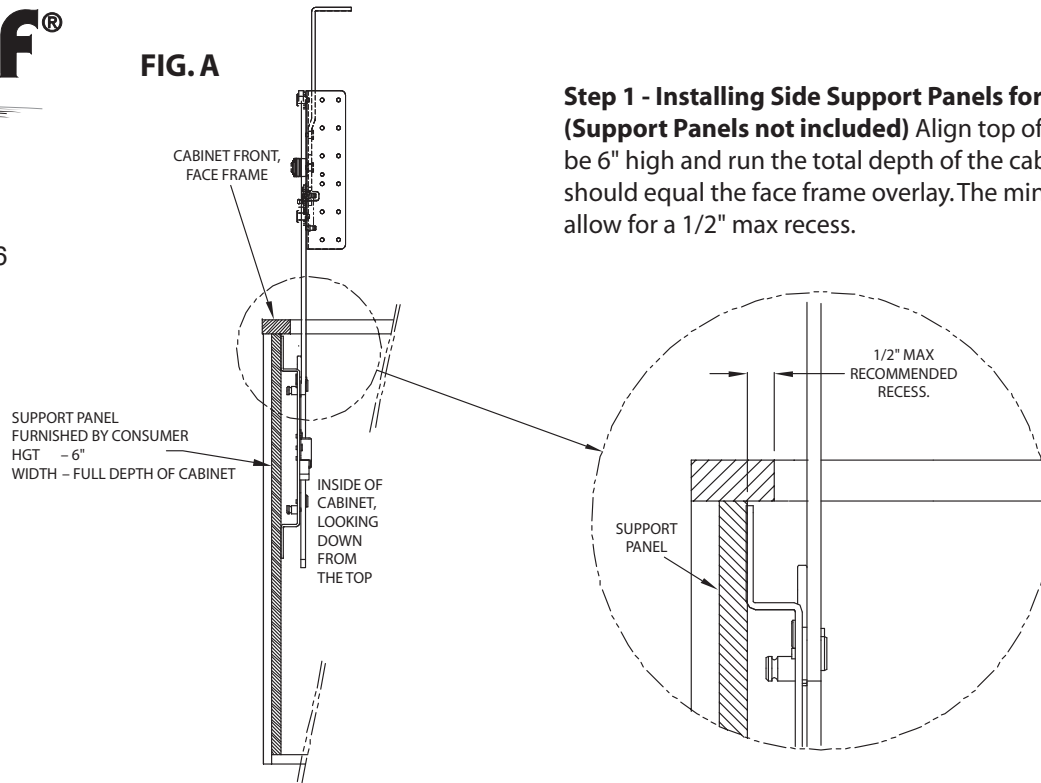

Step 1 - Installing Side Support Panels for Face Frame Cabinets – See FIG. A, (Support Panels not included) Align top of side panel with top of cabinet. Side panels should be 6" high and run the total depth of the cabinet. The maximum thickness of the side panel should equal the face frame overlay. The minimum thickness of the side panel should allow for a 1/2" max recess.

WARNING
 This is a spring loaded product and can cause severe harm if not handled properly during installation.

Step 2 - Installing Side Mounting Brackets - See FIG. B

Mark and Pre-drill two 3/32" pilot holes 1/2" deep into the side support panel. The first hole should be 3/8" from inside of face frame (front of cabinet on frameless cabinet), and 4-1/2" down from the top of the cabinet). The second hole is located parallel from the first hole location 11-3/8" towards rear of cabinet. Mount side mounting bracket to cabinet side panel by aligning outside middle hole locations with the holes that you have just pre-drilled. Fasten with 2 - #10 x 3/4" wood screws. Fasten 6 additional #10 x 3/4" wood screws to additional locations on side mount bracket. **NOTE:** Side mounting brackets must be installed parallel with the top of the cabinet (level) for proper function. Repeat this step for other side mounting bracket.

NOTE 2A

Distance from top of cabinet is determined by height and length of accessory. 4-1/2" will allow adequate clearance for 6 qt. Kitchen Aid® Stand Mixers. Side mounts can be positioned higher if using lift for smaller appliances.

FIG. B

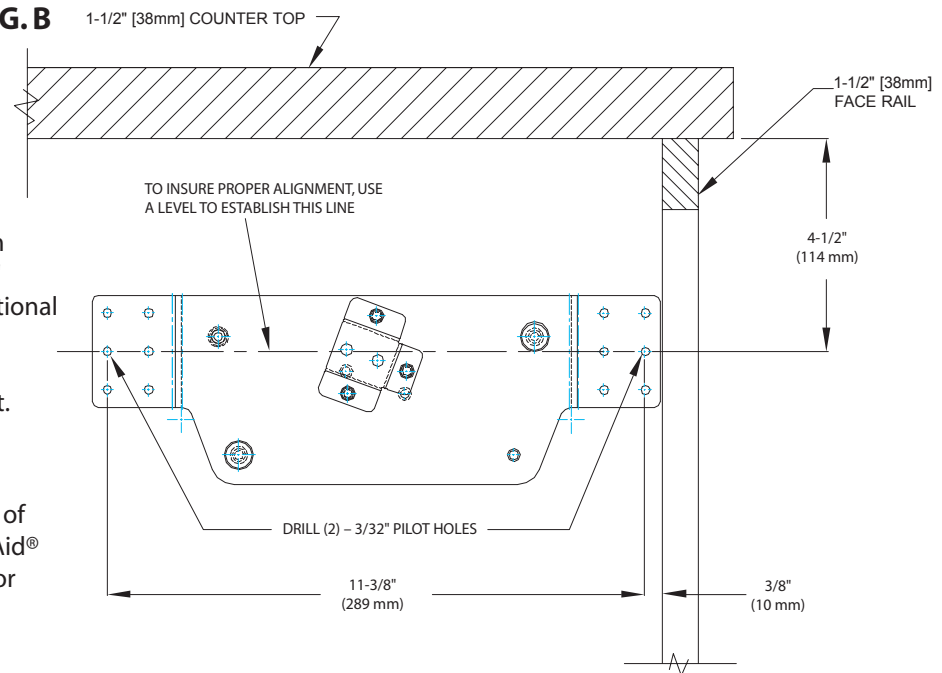

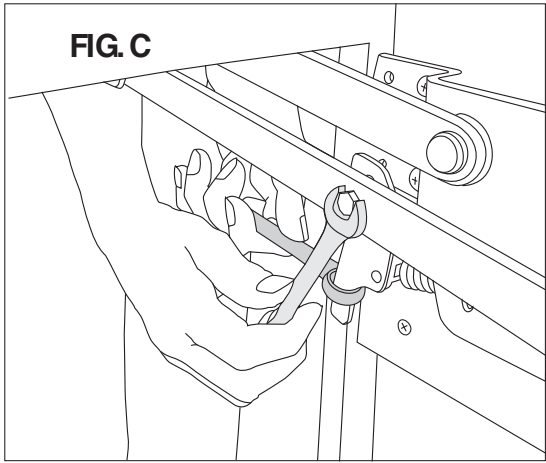

Step 3 - Adjusting Spring Tension – See FIG. C & D

This heavy duty mixer lift is equipped with three adjustable spring tension settings. 0-20, 20-30, and 30-60 lbs. This unit is shipped with the spring settings set to the middle setting. To adjust tension, remove set bolt with 10 mm open end wrench while holding tension on adjustment lever with 12 mm box end wrench. **DO NOT** release holding tension until after the set bolt is in the desired location. With bolt removed, adjust to desired setting. Reinstall set bolt, and tighten securely. Repeat with other side mount bracket.

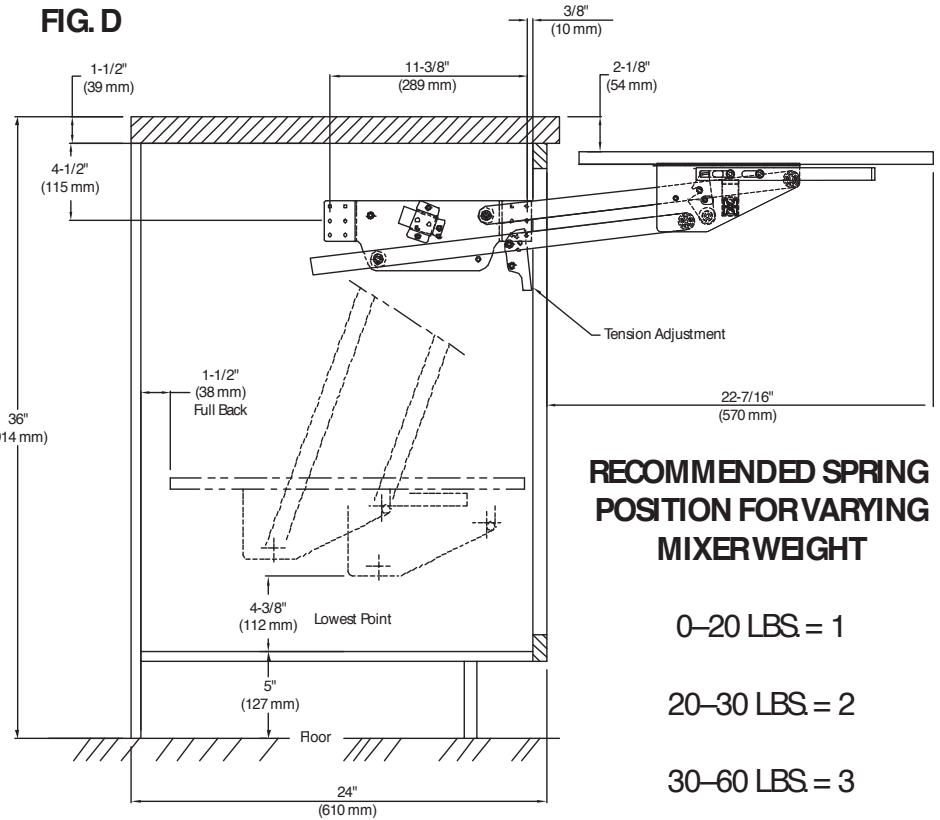

RECOMMENDED SPRING POSITION FOR VARYING MIXERWEIGHT

0–20 LBS. = 1

20–30 LBS. = 2

30–60 LBS. = 3

Step 4 - Determining Shelf Size (shelf not included)

Shelves should be a minimum of 3/4" thick by 20-1/2" in length. The width of the shelf is determined by measuring the width between the side mounting brackets "D" minus 1-1/4". See FIG. E

FIG. E

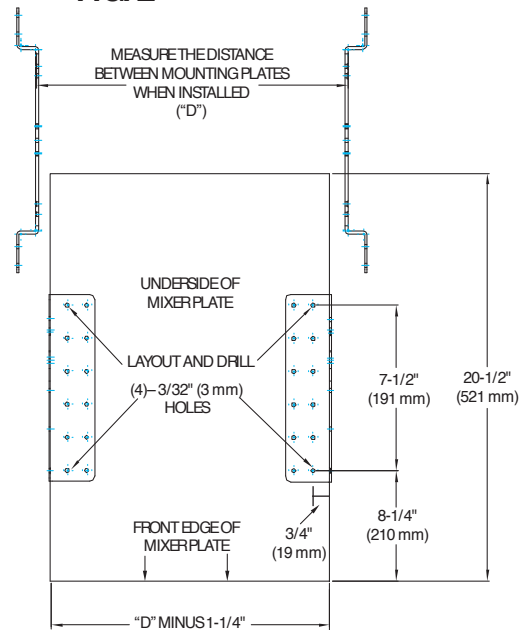

Step 5 - Mounting Shelf – FIG. E

NOTE: Pre-drilling first four hole locations will ensure proper function of mixer lift. Mark hole locations for the front screws by measuring in 3/4" from the side of the shelf and 8-1/4" from the front edge of the shelf. Mark rear screw locations by measuring up 7-1/2" from the first set of marks. Pre-drill 3/32" pilot holes 1/2" deep into shelf. Turn shelf over and mount to mounting brackets with 4-(#10 x 1/2") wood screws. Attach four additional (#10 x 1/2") mounting screws from underneath shelf to other available hole locations.

NOTE: FIG. F
Mixer clearance dimensions

FIG. F

